



Data Sheet

Solar panels

RS stock numbers 194-082 , 194-098, 194-105, 194-111, 194-127, 194-133
194-149, 194-161, 194-183, 768-071, 768-087

A range of commercial grade thin film amorphous silicon and industrial grade polycrystalline photovoltaic modules. These panels are suitable for charging both nickel cadmium and dryfit batteries.

Principle of operation

Solar panels work on the principle of the photovoltaic effect. The photovoltaic effect is the conversion of sunlight into electricity. This occurs when the PV cell is struck by photons (sunlight), 'freeing' silicon electrons to travel from the PV cell, through electronic circuitry, to a load (Figure 1). Then they return to the PV cell, where the silicon recaptures the electron and the process is repeated.

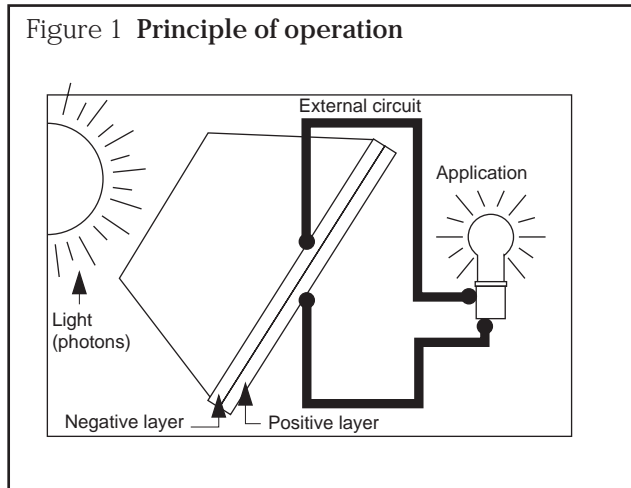

Amorphous silicon

Solarex thin film amorphous silicon modules are manufactured using automated processes similar to those used for semiconductor manufacturing. These processes result in a monolithic module precision-layered with conductive and semiconductive films. These films are laser-scribed, using a patented method, into individual solar cells. The laser's ability to scribe cleanly and precisely produces a superior product in several respects:

- Cell divisions are very narrow, allowing more module surface to be devoted to power production. Thus, a module of given size generates more power.
- Voltage characteristics and overall performance at low light levels are improved.

The series and parallel connections between cells (which determine the modules voltage and current output) are completed internal to the module (Figure 2), resulting in an ultra-reliable module without solder joints.

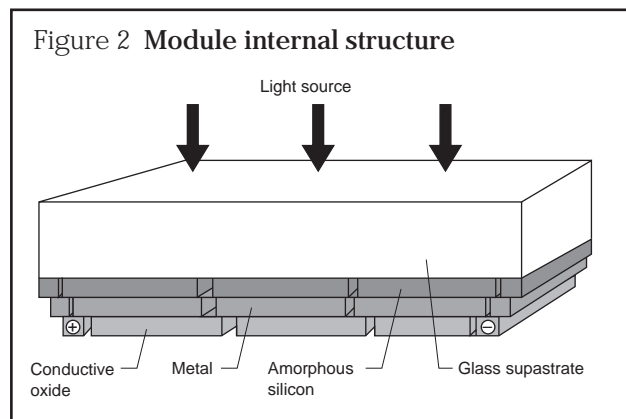

Polycrystalline silicon

Polycrystalline silicon cells are manufactured using 99.999% pure silicon feedstock nuggets available to the semiconductor chip manufacturers. The nuggets are melted down in a vacuum furnace with a little boron and allowed to cool very slowly so that a pure crystal lattice of P-type material is formed. The resulting block is quartered and then sliced into 0.2mm wafers using either a hole saw or a wire saw (Figure 3).

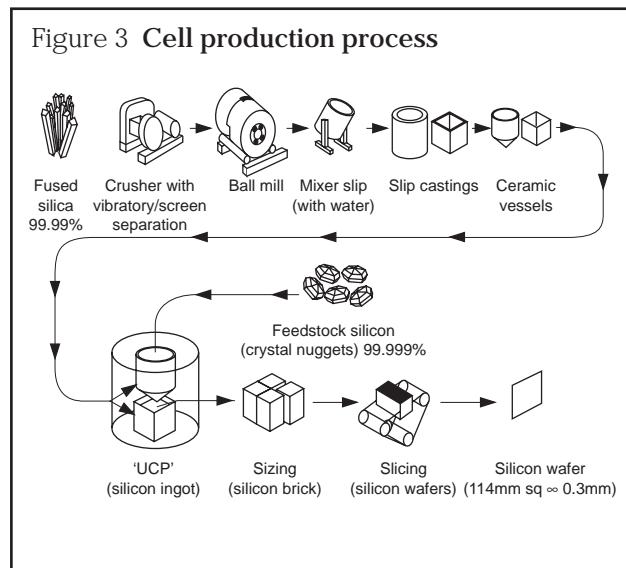

By a patented process the N-type material is formed as a very thin layer on one face of each wafer by spraying with a phosphorous compound gas and baking. This is followed by the addition of an anti-reflective filter coating to the upper surface and conductive layers to both faces. The layer on the front face is optimised in the form of a grid in order to allow the maximum amount of light to pass through to the N-type material whilst distributing the maximum number of electrons (Figure 4).

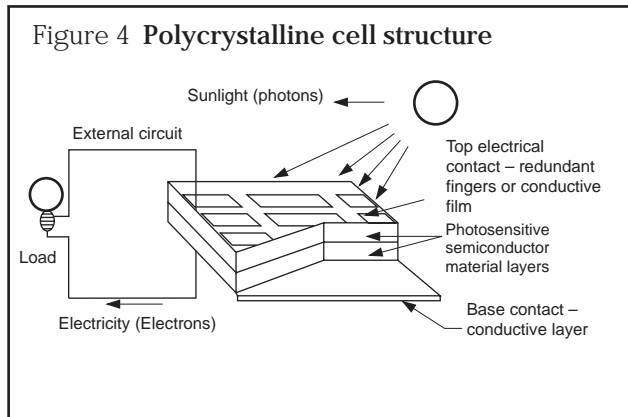

Cells are then tested and matched together with cells of similar performance for building up into series and parallel matrices to give the PV module the desired electrical characteristics.

Construction

Amorphous silicon solar plate (RS stock no. 194-098)

This amorphous solar plate is a monolithic construction consisting of several layers of conducting and semi-conducting materials deposited onto a solar grade glass superstrate. Each plate comes unframed with integral flying leads.

Low/Medium power amorphous modules (RS stock nos. 194-105 and 194-111)

These amorphous silicon solar modules consist of several layers of conducting and semi-conducting materials deposited onto a solar grade glass superstrate. Each module comes complete with a low profile impact reinforced LEXAN™ frame which protects the back and edges of the panel and 1.2m of 2 core 18awg flying leads.

Main features of the panels:

- **Full laser patterning:** A patented process using a computer-controlled laser interconnects all solar cells. This maximises module active area and cell current while minimising the area of the interconnects.
- **Laser isolation:** The plate is encircled by a laser scribe to establish reliable isolation. In the final unit, each part is surrounded by a thin, inactive border that acts as a barrier to edge corrosion.
- **Black appearance:** A patented optical coupling technology, combined with a tightly controlled manufacturing process, creates uniform black appearance.
- **Tin-oxide glass coating:** This patented process offers exceptionally uniform conductivity and light absorption.

Polycrystalline panels

Low power modules

(RS stock nos. 194-127 and 194-133)

These modules consists of high efficiency polycrystalline silicon wafers bonded to an aluminium substrate which is laminated between an ethylene vinyl acetate front sheet and a tough EVA Tedlar™ backsheet. Each module comes complete with a black plastic frame, an integral stand and 0.8m flying leads.

Medium/High power modules

(RS stock nos. 194-149, 194-161, 194-183, 768-071 and 768-087).

These modules have the same basic construction as the low power modules.

Features of these panels include:

Solarex Mega™ Cell

- Advanced polycrystalline technology
- 11.4cm × 11.4cm cell generates superior current.

Reliable outside bussing

- Extends module life
- Resists electrical breakdown
- A unique, patented titanium dioxide AR (anti-reflective) coating for optimum light absorption and power output
- Temperature range -40°C to +90°C or -40°C to +85°C at 85% relative humidity.

Framed versions

Tempered low-iron glass

- High transmissivity
- Hail and wind resistant to JPL block V standards
- Will withstand hailstone of 25.4mm diameter at a terminal velocity 52mph.

Heavy-duty frame

- Corrosion resistant aluminium alloy
- Architectural grade bronze anodised finish
- Withstands 129mph (208km/h).

Weatherproof junction box (20W, 32W and 53W versions only)

- NEMA 4X rated. UL rated terminal block
- Industry standard openings and fittings.

Generous frame clearance

- Prevents electrical breakdown
- Improves module reliability.

Unframed version

Low profile and lightweight

- The unframed types have a low profile of approximately 9mm and are lightweight, the 18W version weighs only 1.49kg.

Simple photovoltaic system

A photovoltaic (PV) system may have a minimum of two components, the module and the load to be powered. An example of such a system would be a simple ventilation fan driven directly by a module during hot and sunny weather. For twenty-four hour a day operation a battery and blocking diode are required, whilst for UK 'all year round operation' a voltage regulator is also recommended in order to protect the battery from the effects of overcharge, typically during the summer.

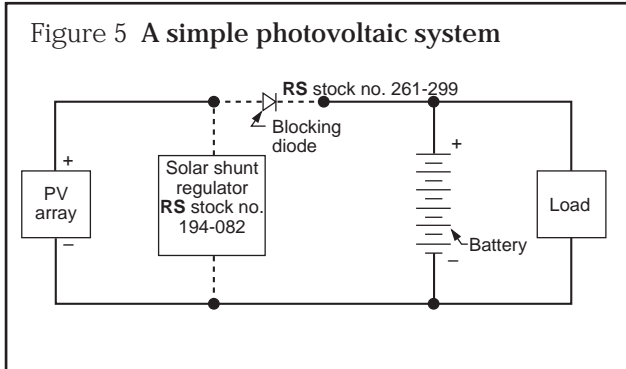

Note: The solar regulator includes a blocking diode and therefore a blocking diode should only be incorporated in a system when the solar regulator is not being used.

Spectral sensitivity of silicon cells

Figure 6 shows the relative response of crystalline silicon cells to the ultra-violet, visible and infra-red spectrum. Response is fairly even to most of the visible wavelengths and the near infra-red. Amorphous (thin-film) silicon favours the blue end of the spectrum.

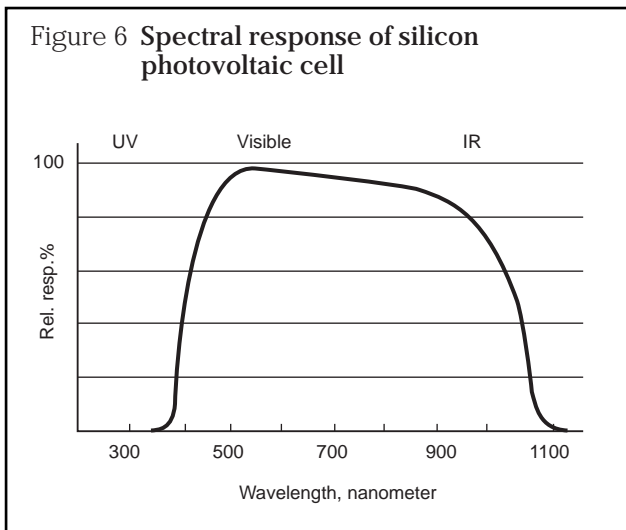

The crystalline cells are made from boron doped silicon wafers and are 12% efficient. The amorphous range of modules is manufactured using automated 'thin film' processes where precision layers of conductive and semi-conductive materials are sprayed onto glass and laser scribed to produce individual cells with an efficiency of 7%. All modules are optimised for daylight operation where current is proportional to light intensity and voltage rises very quickly at low light intensities. Both the amorphous and polycrystalline panels will operate in most UK daytime weather conditions.

Electrical specifications

Standard test conditions (STC) – the power of a module is given at STC which is defined as follows:

1. A light intensity of 1 kW/m^2 (equivalent to full sun).
2. A spectral distribution of AM 1.5 (AM – Air Mass = $1/\cos\theta$ where θ is the angle of the sun to the vertical).
3. A cell temperature of 25°C .

The definition of air mass is as follows:

Air mass, defined as $1/\cos u$ (where u is the angle between the sun and directly overhead) is a useful quantity in dealing with atmospheric effects. Air mass indicates the relative distance that light must travel through the atmosphere to a given location. Because there are no effects due to air attenuation immediately outside the earth's atmosphere, this condition is referred to as air mass zero (AM0). Air mass one (AM1) corresponds to the sun being directly overhead. Air mass 1.5 (AM1.5), however, is considered more representative of average terrestrial conditions and is commonly used as a reference condition in rating photovoltaic modules. Figure 7 shows the relative distance through the earth's atmosphere that the sun's rays must pass at two times during the day.

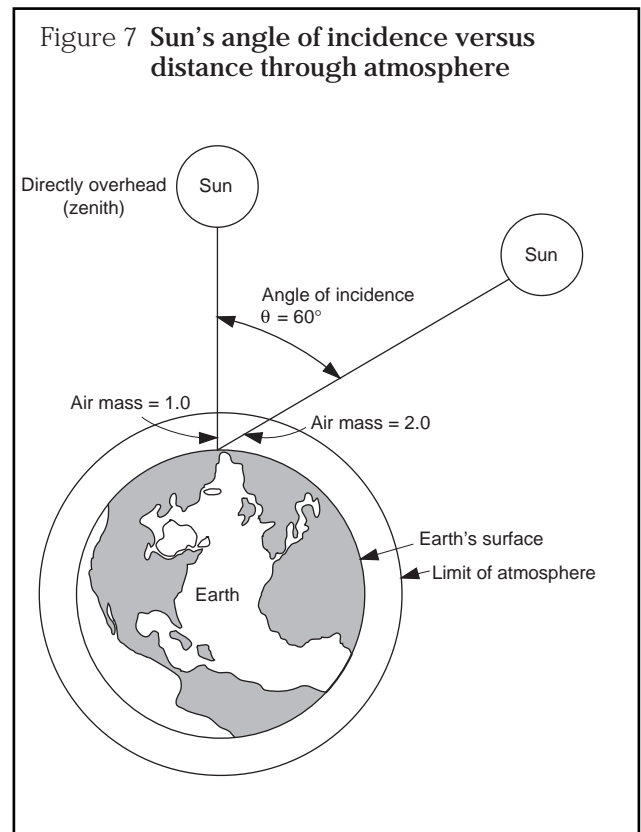

The value of air mass at any given time and location can be easily calculated using the relations shown on next page. The higher the value of air mass, the greater the attenuating effect of the atmosphere.

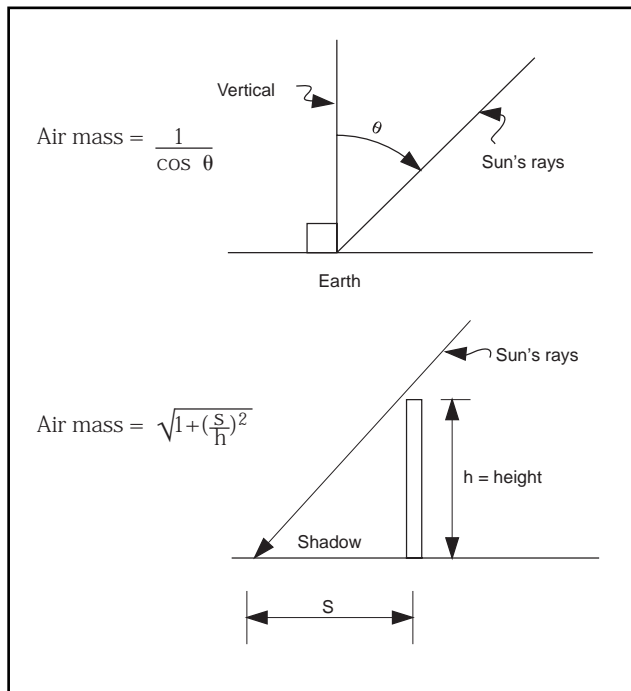

Guaranteed performance – all modules carry a limited warranty covering performance:

Crystalline products – are guaranteed to produce at least 90% of the specified minimum power output for a period of 5 years.

Amorphous products – are guaranteed to produce at least 80% of the specified I_{mp} (current at maximum power) at STC with the voltage fixed at V_{mp} .

Electrical characteristics at STC

Small low power modules

Model RS stock nos.	MSX-005 194-127	MSX-01 194-133	SA-0640 194-098
Specified load voltage (Vld)	3.3V	7.5V	7.5V
Nominal battery voltage	2.4V	6V	6V
Typical current at Vld (Ild)	150mA	150mA	45mA
Open circuit voltage (Voc)	4.6V	10.3V	12.0V
Short circuit current (ISC)	160mA	160mA	54mA
Temperature coefficient of voltage per °C	-16mV	-37mV	-30mV
Temperature coefficient of current per °C	0.15mA	0.15mA	0.05mA

Medium to high power modules

The medium to high power modules (table below) are labelled detailing the individual characteristics of their actual performances at STC. The power output of NOCT – Normal Operating Cell Temperature – at an ambient temperature of 20°C is also printed on the label.

Notes: 1. The 20W, 32W and 53W versions are suitable for both 6 and 12V operation and are user configurable, see installation details.

2. The MSX light series are the unframed versions.

Model RS stock nos.	SA-1 194-105	SA-5 194-111	MSX-5 194-149	MSX-10 194-161	MSX-20 194-183	VLX-32 768-071	VLX-53 768-087
V_{pp} (V)	17.5	17.5	17.5	17.5	17.1	17.2	17.2
I_{pp} (mA)	80	20	270	580	1170	1860	3080
V_{OC} (V)	24.0	23.0	21.2	21.2	20.8	21.3	21.3
I_{SC} (mA)	110	340	290	600	1270	2010	3330
mV/C of V_{OC}	-65	-60	-72	-72	-73	-73	-73
μ A/C of I_{SC}	10	300	275	500	1200	1500	2500
P_{max} @ NOCT - mA			3.1	7.3	18.5	29.1	48.2
I_{pp} @ NOCT - mA			275.5	590	1194	1896	3140

Legend: V_{pp} – Voltage at peak power
 I_{pp} – Current at peak power
 V_{OC} – Open circuit voltage
 I_{SC} – Short circuit current
mV/C of V_{OC} – Temperature coefficient of open circuit voltage
 μ A/C of I_{SC} – Temperature coefficient of short circuit current

NOCT – Nominal Operating Cell Temperature – 49°C (VLX Modules)
– 45°C (MSX Modules)

I-V characteristics with varying light intensity

Polycrystalline cells each give approximately 0.45 Volts when illuminated dependent upon the light intensity and the load but independent of surface area. The important characteristic which makes them so suitable for supplying electrical power is that the voltage builds up quickly to a reliable plateau at very low light levels (about 8% of peak intensity). This means that voltages suitable for battery charging are reached even on a dull day. Current, however, is directly proportional to both light intensity and surface area.

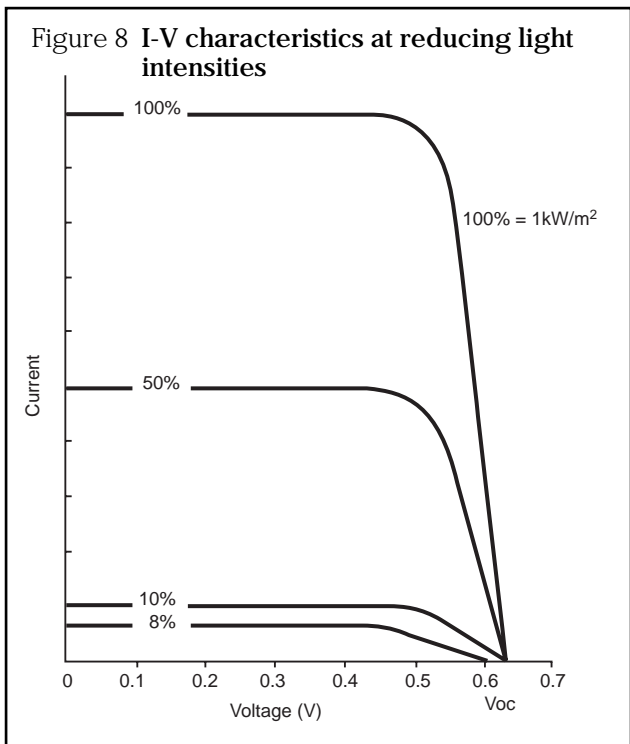

The graph above shows that there is no significant drop in cell voltage until insolation drops to 80W/m².

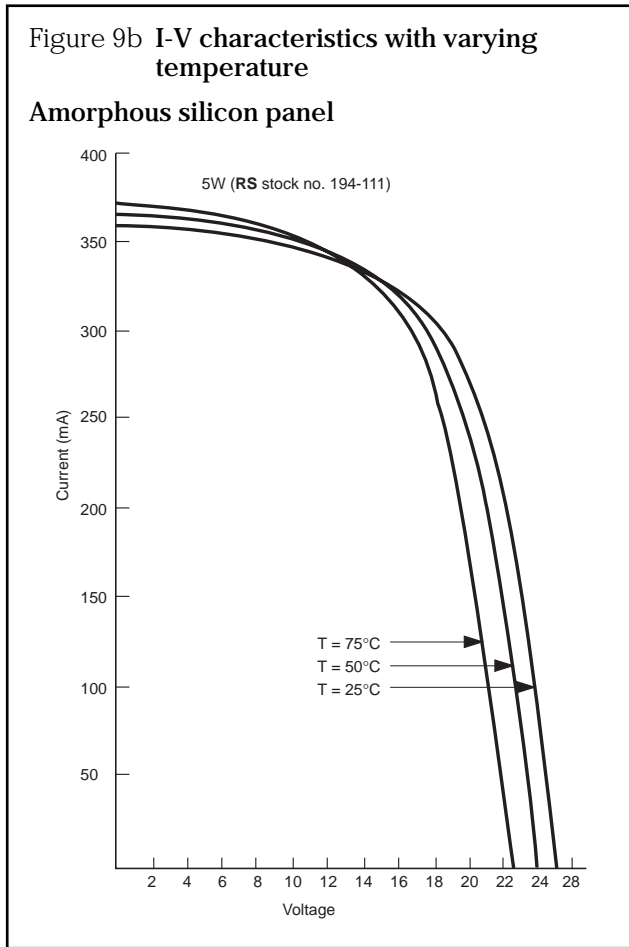
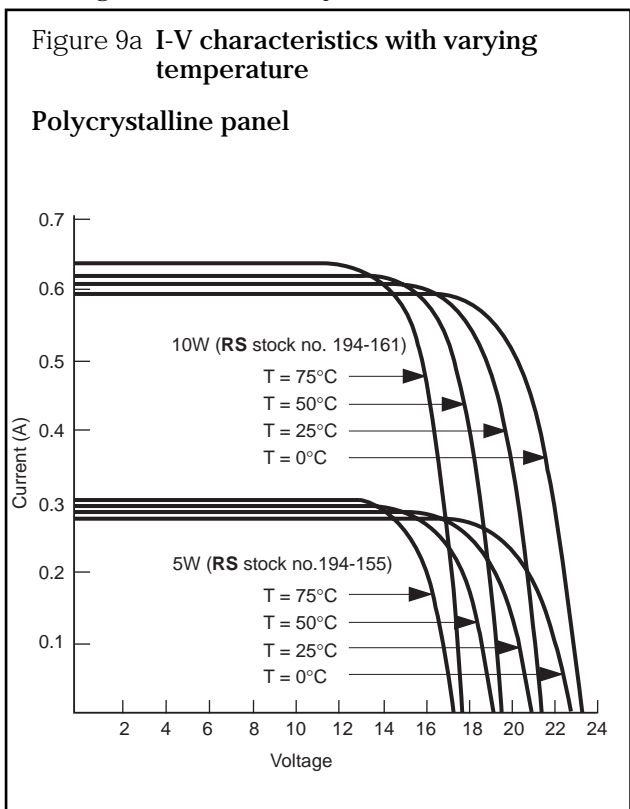

Design considerations for the mounting and installation of the small low power modules

Great care must be exercised during the design stage to ensure that both the edges and rear of OEM (frameless) modules are protected from the environment as well as insulating them from stress through dynamic, static or thermal sources.

Active area

A modules active area – the frontal area that generates electrical power – is a critical design consideration in using any photovoltaic product. If this area is covered by a mounting bezel, power may be reduced and the product may cease to function. For optimal performance, the active area must never be shaded.

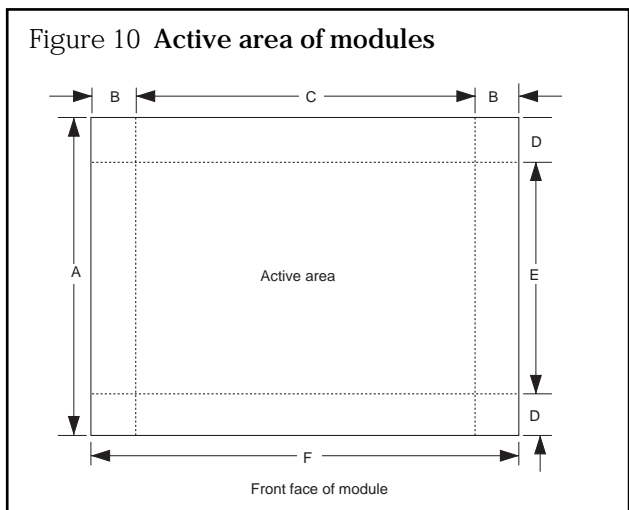

Active area dimensions

Type	A (mm)	B (mm)	C (mm)	D (mm)	E (mm)	F (mm)
(RS stock no. 194-105) MSX-005	114.3	7.49	57	9.86	95.8	71.88
(RS stock no. 194-111) MSX-01	127	5.84	115.32	10.39	106.22	127
(RS stock no. 194-098) SA-0640	54.86	6.35	139.7	3.176	48.52	152.4

Mechanical and dimensional details for the medium/high power modules

1W amorphous module (RS stock no. 194-105)

Mechanical characteristics

Weight: 0.4kg

Dimensions: Dimensions in brackets are in centimetres. Unbracketed dimensions are in inches.

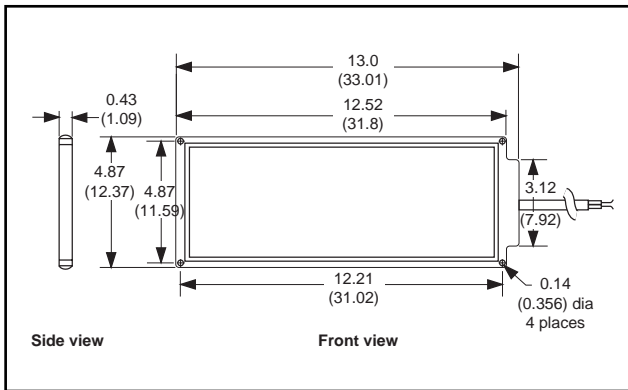

5W amorphous module (RS stock no. 194-111)

Mechanical characteristics

Weight: 1.5kg

Dimensions: Dimensions in brackets are in centimetres. Unbracketed dimensions are in inches.

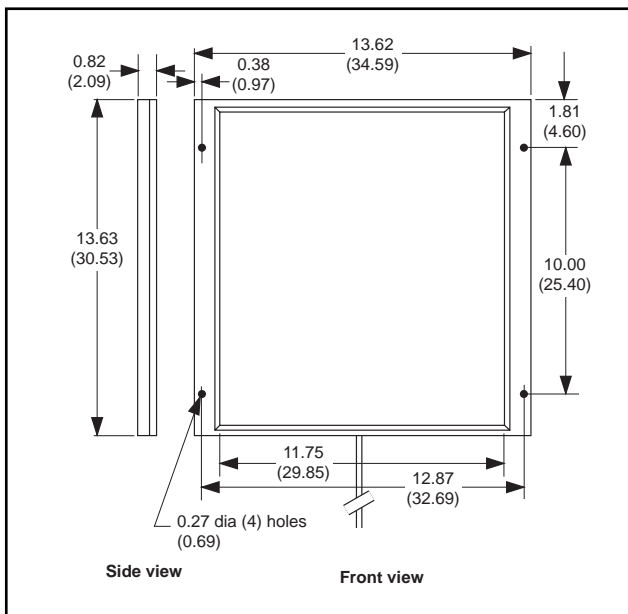

Mechanical characteristics

Output cable: 15 feet long, AWG 18-2, polyethylene jacketed.

Weight:

RS stock no. 194-161 MSX-10 1.5kg
RS stock no. 194-149 MSX-5 0.77kg

Dimensions: Dimensions in brackets are centimetres. Unbracketed dimensions are in inches.

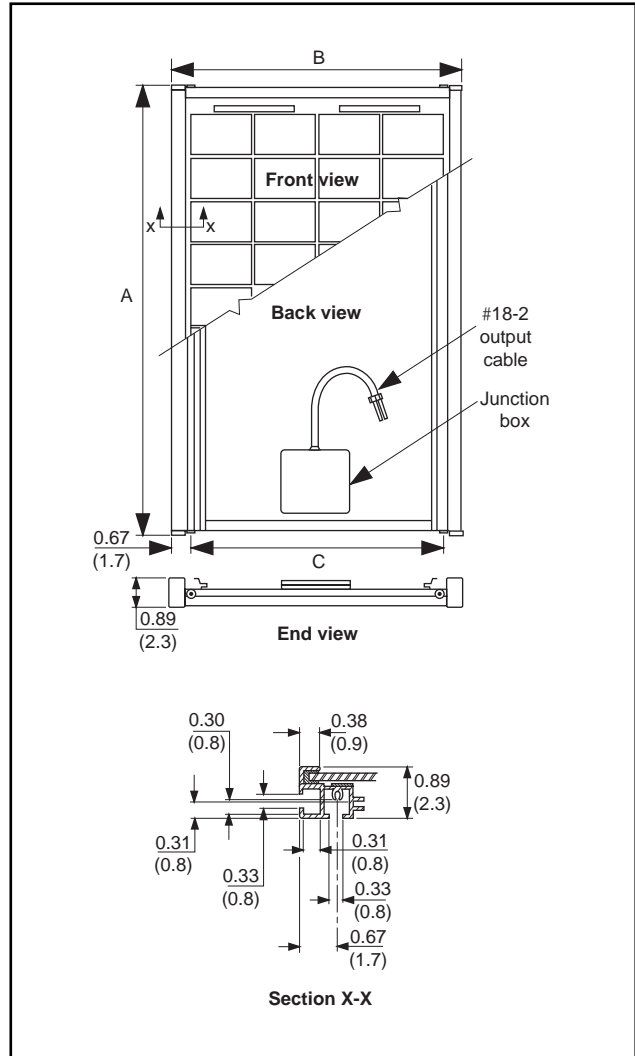

	Dim. A	Dim. B	Dim. C
MSX-5	9.82	10.59	9.25
(RS stock no. 194-149)	(24.9)	(26.9)	(23.5)
MSX-10	16.54	10.59	9.25
(RS stock no. 194-161)	(42.0)	(26.9)	(23.5)

Mechanical characteristics

Weight:

RS stock no. 194-183 MSX-20 2.95kg

Dimensions: Dimensions in brackets are centimetres. Unbracketed dimensions are in inches.

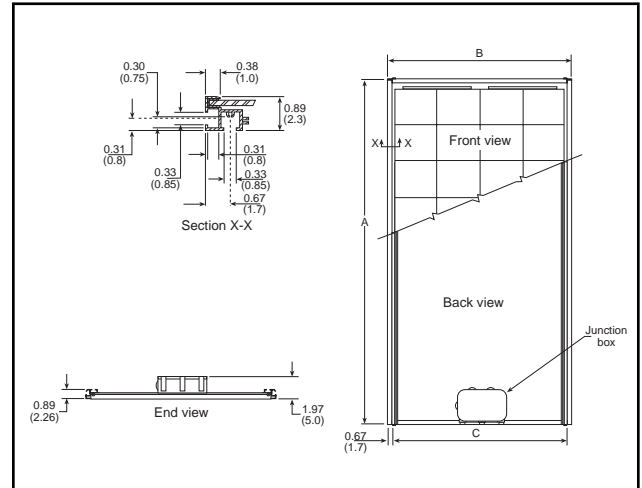
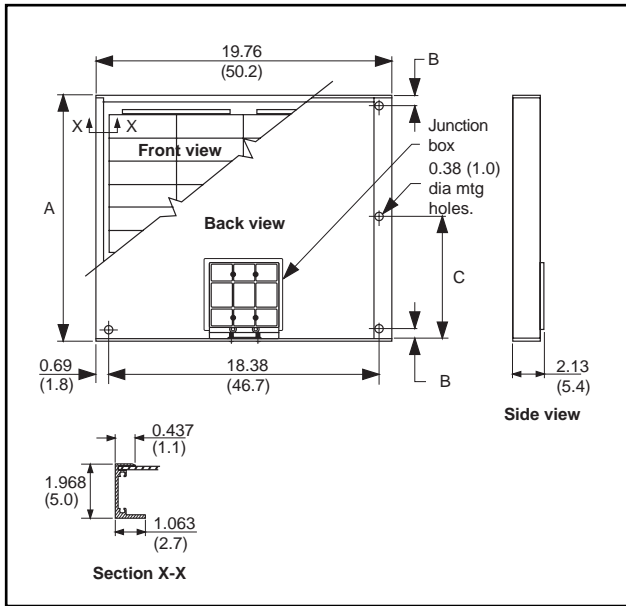

	Dim. A	Dim. B	Dim. C
VLX-32 (RS stock no. 768-071)	23.28 (59.1)	19.72 (50.0)	18.38 (46.7)
VLX-53 (RS stock no. 768-087)	36.88 (93.7)	19.72 (50.0)	18.38 (46.7)

	Dim. A	Dim. B	Dim. C
MSX-20	16.5	0.75	8.29
(RS stock no. 194-183)	(42.1)	(1.9)	(21.1)

Mechanical characteristics

Weight

RS stock no. 768-071 VLX-32 3.5kg

RS stock no. 768-087 VLX-53 5.5kg

Dimensions: Dimensions in brackets are centimetres. Unbracketed dimensions are in inches.

Installation and mounting

Orientation

When installing photovoltaic modules, be aware that they generate maximum power when facing the sun directly. The fixed position which approximates this ideal over the course of the year, thus maximising annual energy production, is facing due south (in the northern hemisphere) or due north (in the southern hemisphere) at the angle listed in the table below.

Note: These orientations are true, not magnetic north and south.

Tilt angle

The table below shows the fixed angle above horizontal at which modules should be installed in order to maximise annual energy output. At some installations, it may be cost-effective to adjust the tilt seasonally. At most latitudes, performance can be improved during the summer by using an angle flatter than the charts recommendation; conversely, a steeper angle can improve winter performance.

If modules are not cleaned regularly, it is recommended that they are not mounted at an angle flatter than 15°. Flatter angles cannot take full advantage of the cleansing action of rainfall.

Latitude of site	Tilt angle
0-4°	10°
5-20°	Add 5° to local latitude
21-45°	Add 10° to local latitude
45-65°	Add 15° to local latitude
65-75°	80°

Shading

Locate modules so they are as free as possible from shading during all seasons, particularly during the middle (the most energy-productive) part of the day.

Mounting

The amorphous modules and the polycrystalline light modules can be mounted via the integral holes. It is important that the mounting hardware is not over tightened or that the module is bent during installation.

Modules can also be mounted on a flat wooden surface, such as 1/2in thick plywood. Such an installation, however, prevents natural airflow from cooling the back of the module, an effect which enhances module performance slightly. If this enhancement is desired, the installation should allow airflow across the module back.

The 5W and 10W polycrystalline panels have a multi-mount frame. This consists of dual channels oriented parallel to the edge and back of the module. The channels accept the heads of 5/16in or 8mm hex bolts, and allow the module to be rear- or side-mounted. The channels prevent the bolt heads from turning.

The 20W, 32W and 53W polycrystalline panels have a universal mount frame. This frame can be mounted via the six 10mm holes in the dual channels. To mount the module on a pole use the two centre holes.

MSX-20, VLX 32 and 53 modules – wiring for 6V or 12V operation

The two strings of 18 cells which make up the modules may either be connected in series or parallel for 12V or 6V operation as shown in Figure 11. Positive conductors have red insulation whilst the negative ones are grey. The module is shipped in 12V configuration. All other finished modules are configured as 12V and cannot be altered.

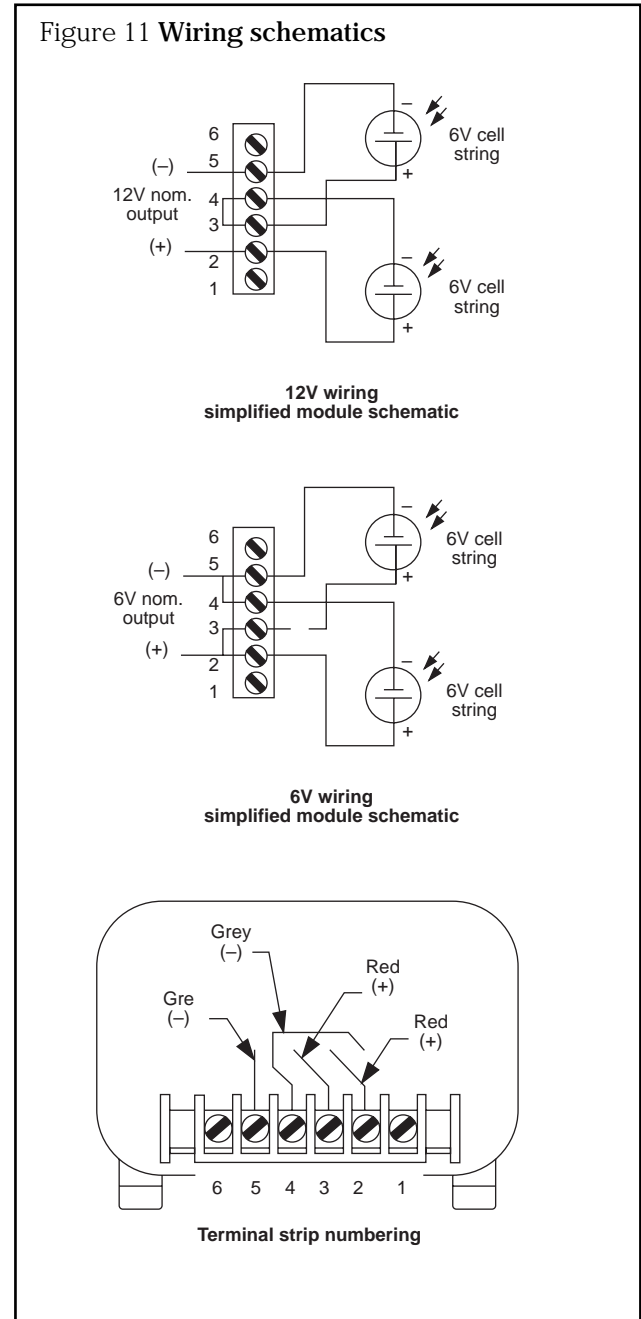

Daily average insolation levels in the United Kingdom

The following tables of mean daily ESH (equivalent sunshine hours) may be used to calculate the size of module required:

Location	(OT)	Equivalent sunshine hours - kWhrs/m ² /day					
		Summer - mean for June			Winter - mean for Dec		
		H	Vs	Sot	H	Vs	Sot
Plymouth	65°	5.56	2.85	4.20	0.69	1.35	1.40
Manchester	68°	5.17	2.80	3.86	0.46	0.88	0.91
Glasgow	71°	4.94	2.76	3.62	0.33	0.64	0.65

Legend: OT - Optimum tilt angle (degrees from horizontal)
 H - Horizontal
 Vs - Vertical south facing
 Sot - South facing at optimum tilt

(Data taken from *Climate in the UK* - ISBN 0 11 412301 2)

Notes:

1. For areas of higher or lower latitude in the UK appropriate insolation levels may be extrapolated from the figures shown.
2. The data above should be used with care as these figures were gained from 'ideal' sites, please consider all the potential performance derating factors listed below.
3. If sizing a system outside the UK then an approximate guide to mean daily wintertime (worst case) insolation levels is given in the following maps:

Figure 12 Worldwide insolation availability maps

These maps indicate worst case (wintertime) solar radiation based on a Solar Array tilted towards the sun at an angle equal to the latitude of the location +15°.

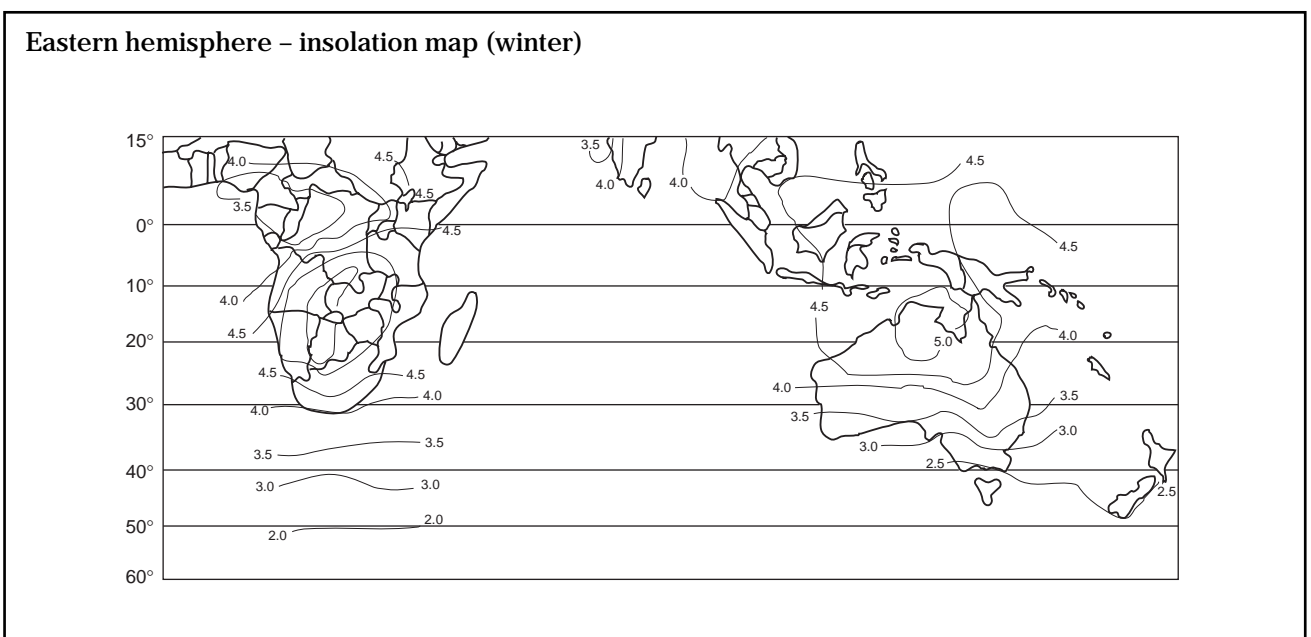
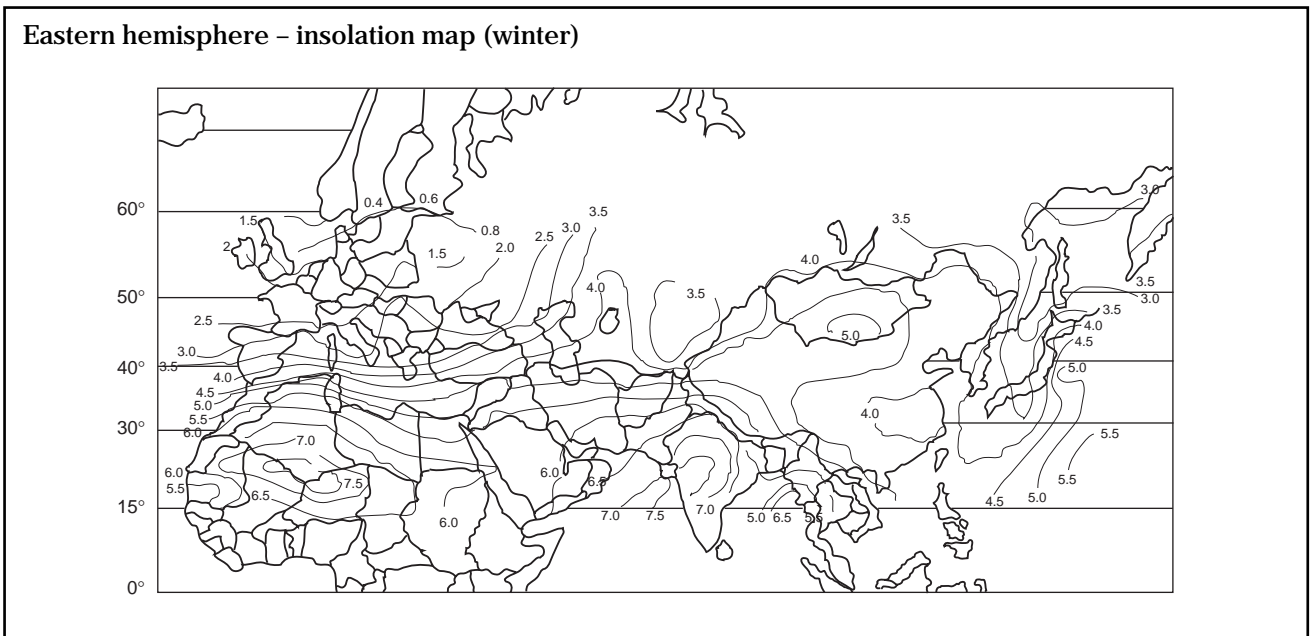

Western hemisphere – insolation map (winter)

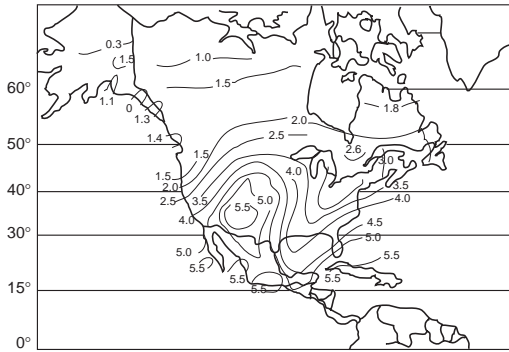

Western hemisphere – insolation map (winter)

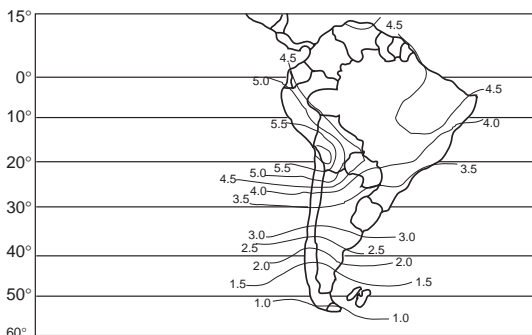

Module performance derating factors

It is appropriate to consider the many factors which can derate the performance of a solar module prior to completing any sizing calculations:

- a) Temperature – as a guide the typical cell operating temperature will be 20°C to 25°C higher than ambient.
- b) Cleanliness – the modules active area should be cleaned off periodically to maintain performance.
- c) Production tolerances – these are catered for with an appropriate safety factor in the sizing calculation.
- d) Reflection/Refraction – if the module is mounted behind glass or some other clear medium then reflection and refraction will typically account for losses of 20%.
- e) Shadowing – during sunny conditions the possibility of shadows falling across the module should be reduced to a minimum as the performance of all cells will be reduced to that with the lowest output.
- f) Azimuth and tilt angle – as an example it will be seen from the UK insolation table above that horizontal mounting gives excellent summer performance but minimal in winter – for best all year round performance the module should be fixed at an angle of latitude +15, facing true south.
- g) Spectral distribution of light – the performance of Solarex modules is optimised for daylight. Performance under artificial light sources must be found by measurement.

Daily system load

In order to ensure reliable system operation all year round it is imperative that the worst case daily load in winter is known. It is also very important to ensure that adequate account is taken of quiescent loads, switching losses and if a voltage regulator is employed its own consumption characteristics.

Battery sizing

The battery stores energy from the module enabling the system load to operate day or night. Due to the vagaries of the weather we must allow for long periods of below average insolation in order to ensure reliable operation. In effect this means that the battery size is calculated to allow for a certain number of days without energy input, the system 'autonomy'. At UK latitudes this should not be less than 20 days.

We must also consider several important points;

- a) that should this situation occur it is not advisable to allow the battery to discharge to 0% capacity
- b) capacity reduces with temperature
- c) the effects of self discharge and charging efficiency may be significant
- d) battery capacity is a function of discharge rate.

Typically, therefore, do not discharge the battery below its 30% charge state and allow for a 10% capacity reduction in winter. Thus a system supplying a load consuming 0.75Ah/day would require a battery capacity of:

$$0.75 \times 20 \times 1.3 \times 1.1 = 21.45Ah$$

Battery choice – The **RS** Dryfit range of sealed lead acid batteries is ideal for solar systems having high charge efficiency, low self-discharge and good recovery from high discharge.

Module sizing

Having determined the load requirements and local insolation the last step is to calculate the size of module required.

$$SA = \frac{L \times SF}{ESH}$$

- SA = System Amps (to be provided by module)
- L = Load
- SF = Safety factor (use 1.2)
- ESH = Equivalent sunshine hours (kWhrs/m²/day)

Example: Thus for a system consuming 0.75Ah/day all year round in the Manchester area with a module facing true south, tilted at latitude +15 (= 68) and unshadowed:

$$SA = (0.75 \times 1.2)/0.91 = 0.99 \text{ Amps}$$

From the table of module performance characteristics we will see that the MSX-18 module has an I_{pp} of 1.06 amps. This is the correct choice as the smaller MSX-10 only has an I_{pp} of 0.58 Amps.

Note: A regulator would be required in this system thus the daily load is inclusive of its power requirements.

Regulation

In the UK with its high ratio of summer to winter insolation it is almost always essential for a solar system to be fitted with a voltage regulator to protect the battery against the effects of overcharge during the long summer days. A regulator would not be required if during the period of operation of the system the daily load was matched to the mean module output. Regulators incorporate blocking diodes that prevent battery discharge through the module at night, so in an unregulated system a blocking diode would be required. A suitable blocking diode would be a 1N5401 (RS stock no. 261-299) 3A, 100V.

Shunt regulator (RS stock no. 194-082)

The performance specifications of the shunt regulator are as follows:

Nominal voltage	12.0V
Maximum input current	6.0A
Shunt set point voltage	13.8V
Quiescent current	<1.0mA
Blocking diode voltage drop	0.4V
Temp. coeff. of output voltage	45mV/deg C

The three output leads are colour coded as follows:

RED	SOLAR MODULE +ve
BLACK	COMMON -ve
YELLOW	BATTERY +ve

Each 1.0mm² lead is 220mm in length and terminated with an M4 spade terminal.

Regulator status is indicated by a single, green LED which is illuminated when the set point voltage of 13.8V is reached and shunting of the module output commences. When battery voltage drops to 12.8V the LED is extinguished and the module output is redirected to the battery.

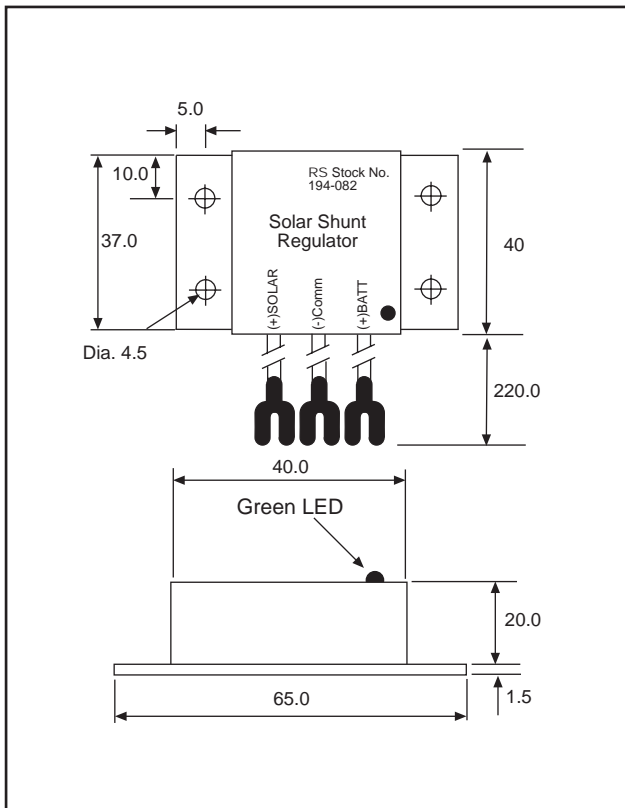

The matrix below provides general guidelines for choosing either a blocking diode or a regulator.

Location	(OT)	Equivalent sunshine hours - kWhrs/m ² /day					
		Summer - mean for June			Winter - mean for Dec		
		H	Vs	Sot	H	Vs	Sot
Plymouth	65°	5.56	2.85	4.20	0.69	1.35	1.40
Manchester	68°	5.17	2.80	3.86	0.46	0.88	0.91
Glasgow	71°	4.94	2.76	3.62	0.33	0.64	0.65

Glossary of solar terms

Air mass - A measure of distance that light travels through the earth's atmosphere.

Ampere-hour - A measure of electrical charge.

Array - A collection of photovoltaic modules, electrically wired together and mechanically installed in their working environment.

Block V - Module qualification tests designed and conducted by the Jet Propulsion Laboratory. Modules undergo electrical performance measurements and mechanical tests, such as thermal cycling, humidity-freezing, cyclic pressure loading, hail-impact and twisted mounting surface requirements.

Blocking diode - A device for preventing a reverse flow of current through photovoltaic modules (also called a series diode or an isolation diode).

Bypass diode - A device placed in parallel with a photovoltaic module or group of modules allowing a route for the current under conditions of shading and cell failure (also called a shunt diode).

Cell efficiency - The ratio of the electrical energy produced by a photovoltaic cell (under full sun conditions) to the energy from sunlight falling upon the cell.

Design tilt - The tilt of the array at which design and sizing calculations are made. Often the design tilt is optimised for energy output under prescribed conditions.

Diffuse radiation - Sunlight received indirectly as a result of scattering due to clouds, fog, haze, dust or other substances in the atmosphere.

Direct radiation - Light that has travelled in a straight path from the sun (also referred to as beam radiation). An object in the path of direct radiation casts a shadow on a clear day.

Fill factor - The ratio of maximum power to the product of open-circuit voltage and short-circuit current. Fill factor is the 'squareness' of the I-V curve shape.

Flat-plate array - A photovoltaic array in which the incident solar radiation strikes a flat surface and no concentration of sunlight is involved.

Grid-connected - An energy producing system connected to the utility grid (also called utility-interactive).

Grounding - Connection to a large conducting body (such as the earth), which is used as a common return for an electrical circuit and as an arbitrary zero potential.

Holes - Vacancies, where electrons should normally be in a perfect crystalline structure.

Hybrid system – A power system consisting of two or more power generating subsystems (e.g. the combination of a wind turbine and a photovoltaic system).

Insolation – The amount of sunlight reaching an area. Usually expressed in watts per square metre per day.

Junction box – A protective enclosure into which wires or cables are led and connected.

Load – Electrical power being consumed at any given moment. The load that an electric generating system supplies varies greatly with time of day and to some extent season of year. Also, in an electrical circuit, the load is any device or appliance that is using power.

Maximum power current (I_{mp}) – The corresponding current for the maximum power point on an I-V curve.

Maximum power point (P_{max}) – The desired operating point on an I-V curve where the product of the current and voltage (power) is maximised.

Maximum power voltage (V_{mp}) – The corresponding voltage for the maximum power point on an I-V curve.

Module – A number of photovoltaic cells electrically wired together, usually in a sealed unit of convenient size for handling and assembling into panels and arrays.

Nominal operating cell temperature (NOCT) – The photovoltaic cell junction temperature corresponding to nominal operating conditions in a standard reference environment of 1kW/m^2 irradiance, 20°C ambient air temperature, 1m/s wind, and electrically open circuit.

Open-circuit voltage (V_{oc}) – The voltage output of a photovoltaic device when no current is flowing through a circuit.

Panel – A number of modules wired together, which in turn, can be wired to other panels to form an array.

Parallel connected – A method of connection in which positive terminals are connected together and negative terminals are connected together. Current output adds and the voltage remains the same.

Peak sun hours – The equivalent number of hours at peak sun conditions (i.e. 1kW/m^2) that produces the same total insolation as actual sun conditions.

Photovoltaic cell – The basic device that converts light into dc electricity; the building block of photovoltaic modules.

p-n junction – The junction formed at the interface between two differently doped layers of semiconductor material, one layer being doped with a positive-type dopant, the other with a negative-type dopant. An electric field is established at the p-n junction which gives direction to the flow of light-stimulated electrons.

Series connected – A method of connection in which the positive terminal of one device is connected to the negative terminal of another. The voltages add and the current is limited to the least of any device in the string.

Short-circuit current (I_{sc}) – The current flowing freely from a photovoltaic cell through an external circuit that has no load or resistance; the maximum current possible under normal operating conditions.

Solar constant – The rate at which energy is received from the sun just outside the earth's atmosphere on a surface perpendicular to the sun's rays. Approximately equal to 1.36kW/m^2 .

Standard test conditions (STC) – Test conditions in a standard reference environment of 1kW/m^2 , 25°C cell temperature, and 1.5 air mass spectrum.

Thick cells – Conventional cells, such as crystalline silicon cells, which are typically from 4 to 17mm thick. In contrast, thin-film cells are several microns thick.

Thin-film cells – Photovoltaic cells made from a number of layers of photo-sensitive materials. These layers are typically applied using a chemical vapour deposition process in the presence of an electric field.

Voltage regulator – A device that controls the operating voltage of a photovoltaic array.

Watt – A measure of electrical power or amount of work done in a unit of time. One Amp of current flowing at a potential of one Volt produces one Watt of power.